

Spanraamketting

O.a. textielindustrie

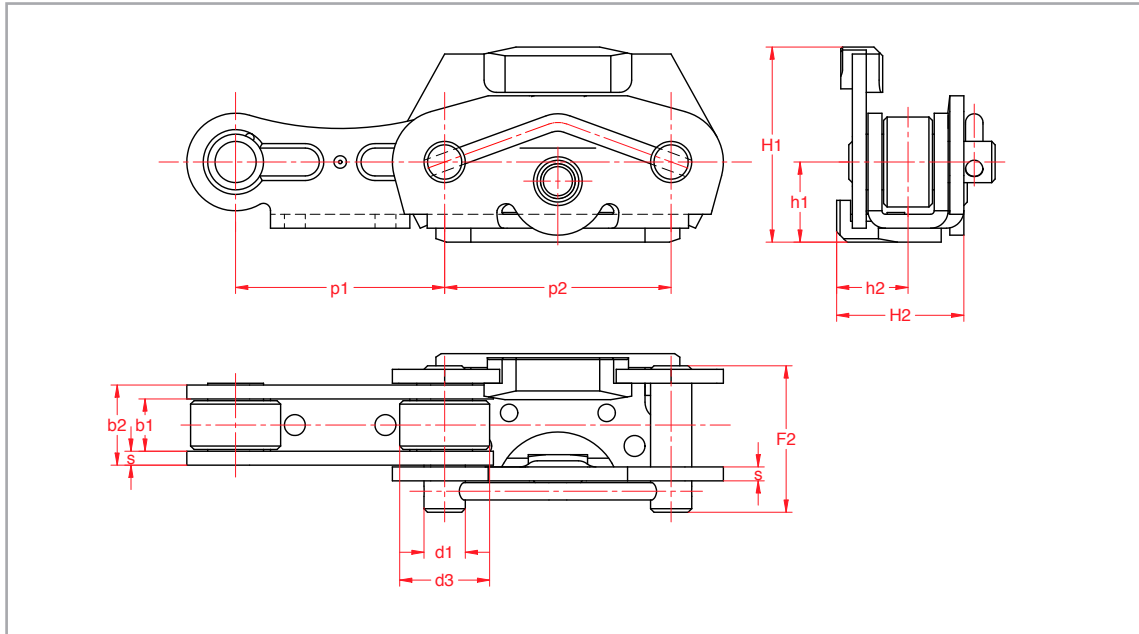

Art.Nr.	p ₁ mm	p ₂ mm	b ₁ mm	b ₂ mm	d ₁ mm	d ₃ mm	F ₂ mm	s mm	H ₁ mm	h ₁ mm	H ₂ mm	h ₂ mm	f cm ²
15620600	60	65	15	23,2	11,83	25,82	42	4	56	23,2	36,25	20,25	0,9

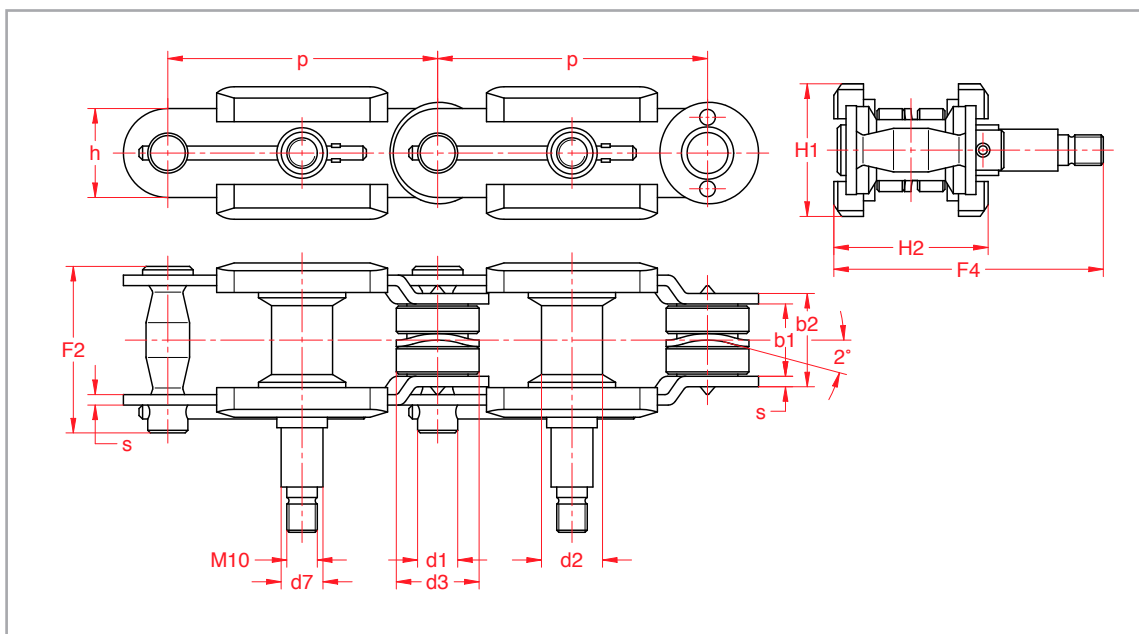

Art.Nr.	p mm	b ₁ mm	b ₂ mm	d ₁ mm	d ₂ mm	d ₃ mm	d ₇ mm	F ₂ mm	F ₄ mm	h mm	s mm	H ₁ mm	H ₂ mm	f cm ²	F _B N	q kg/m
15620900	90	24	32	13,75	20	27,95	13,9	56	88,5	30	4	44	52	1,8	45000	7,0