

Rollenketting

Met U-beugel

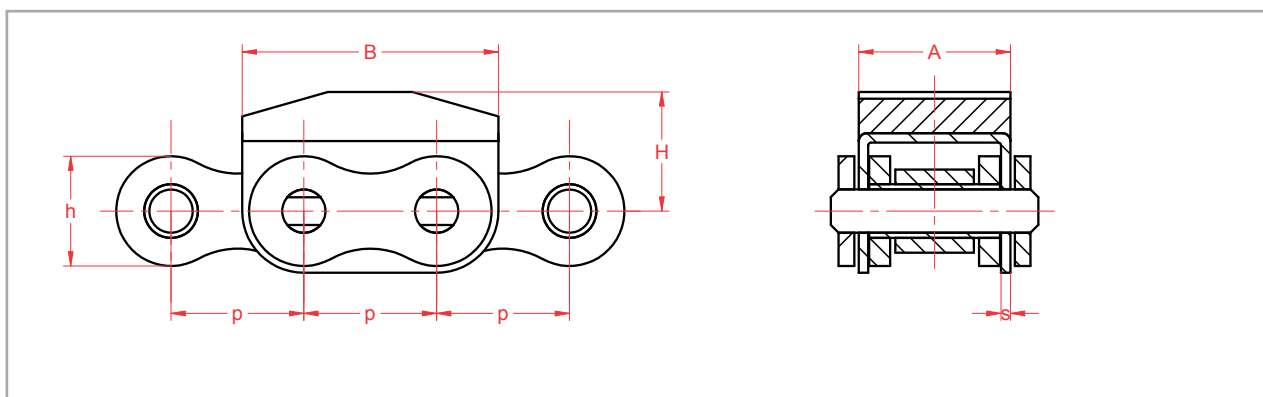
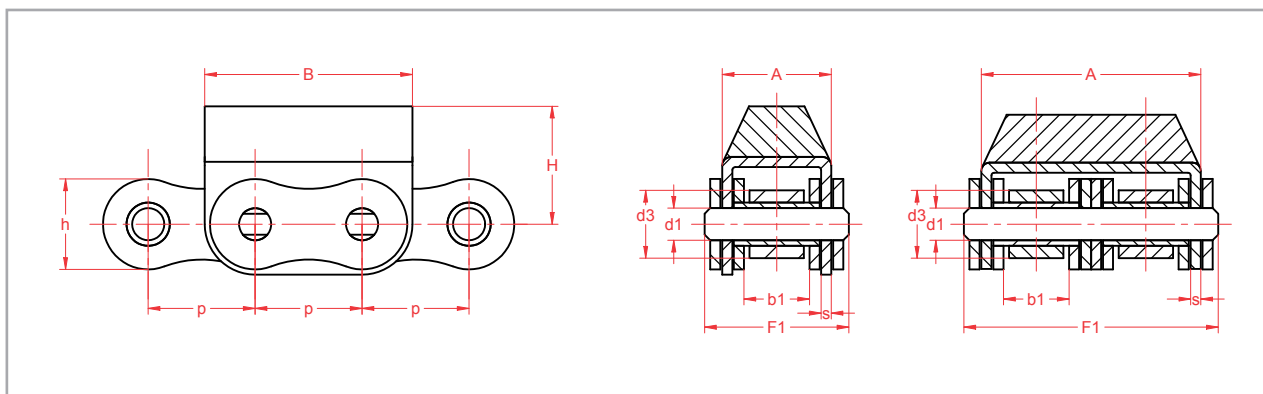

Nr.	Inch	p mm	b ₁ mm min.	d ₃ mm	d ₁ mm max.	F ₁ mm max.	h mm max.	s mm	A mm	B mm	H mm	F _B N min.	q kg/m
08B-1	1/2"	12,7	7,75	8,51	4,45	20	11,8	1,3	14,5	24	12,5	18000	1,19
08B-2	1/2"	12,7	7,75	8,51	4,45	33,5	11,8	1,3	28,4	24	12,5	32000	2,07
10B-1	5/8"	15,875	9,65	10,16	5,08	23,2	14,7	1,5	16,4	30	17	19000	1,62
10B-2	5/8"	15,875	9,65	10,16	5,08	39,7	14,7	1,5	33,3	30	17	44500	2,56
12B-1	3/4"	19,05	11,68	12,07	5,72	25,7	16,1	1,8	19,4	37	21	29000	2,01
12B-2	3/4"	19,05	11,68	12,07	5,72	45,3	16,1	1,8	39,1	35	19,5	57800	3,21
16B-1	1"	25,4	17,02	15,88	8,28	39,7	21	1,8	29	49	21,4	58000	3,97
16A-1	1"	25,4	15,88	15,88	7,92	37,2	24,1	1,8	26,7	48	22,4	42000	3,21
20B-1	1 1/4"	31,75	19,56	19,05	10,19	48	26,4	3,5	36	57	27	85000	6,19
24B-1	1 1/2"	38,1	25,4	25,1	14,63	61,6	33,4	4,5	47	72,6	34	160000	11,25
Type B													
16B-1	1"	25,4						1,8	29	49	21,4		