

Rotary ketting

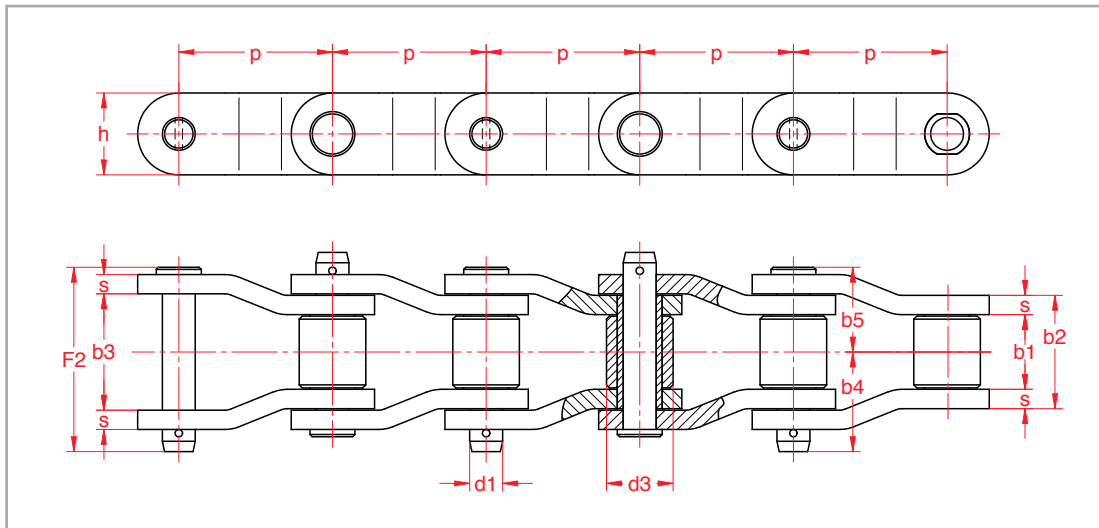

Nr.	p mm	b ₁ mm	b ₂ mm	b ₃ mm	b ₄ mm	b ₅ mm	d ₃ mm	d ₁ mm	h mm	s mm	F ₂ mm	f cm ²	F _B N	q kg/m
2010	63,5	38,1	54,38	54,51	47,8	42,9	31,75	15,9	47	8	91	8,6	270000	13
2510	78,1	38,1	55,2	55,4	53	46	31,75	16	40	8	99	8,66	320000	10
2512	77,9	39,6	59,13	59,26	55,6	47,8	41,28	19,08	60	10	103	10,8	400000	19
2814	88,9	38,1	64,01	64,14	62	55,6	44,45	22,25	60	13,5	118	14,48	600000	25,5
3214	103,2	49,2	76,2	76,8	66,5	57	44,45	22	55	13	124	16,65	620000	22
3315	103,45	49,3	78,28	78,41	71,4	63,5	45,24	23,85	60	15	135	18,9	700000	28
3618	114,3	52,3	81,46	81,58	76,2	65	57,15	27,97	75	15	141	23	860000	38,5
4020	127	69,8	102,39	102,51	90,4	77,7	63,5	31,78	90	17	168	33	1100000	52
4824	152,4	76,2	115,09	115,21	98,6	88,9	76,2	38,13	100	20	188	44,3	1600000	70
5628	177,8	82,6	127,79	127,91	114,3	101,6	86,9	44,48	130	22	216	56,3	2100000	95